

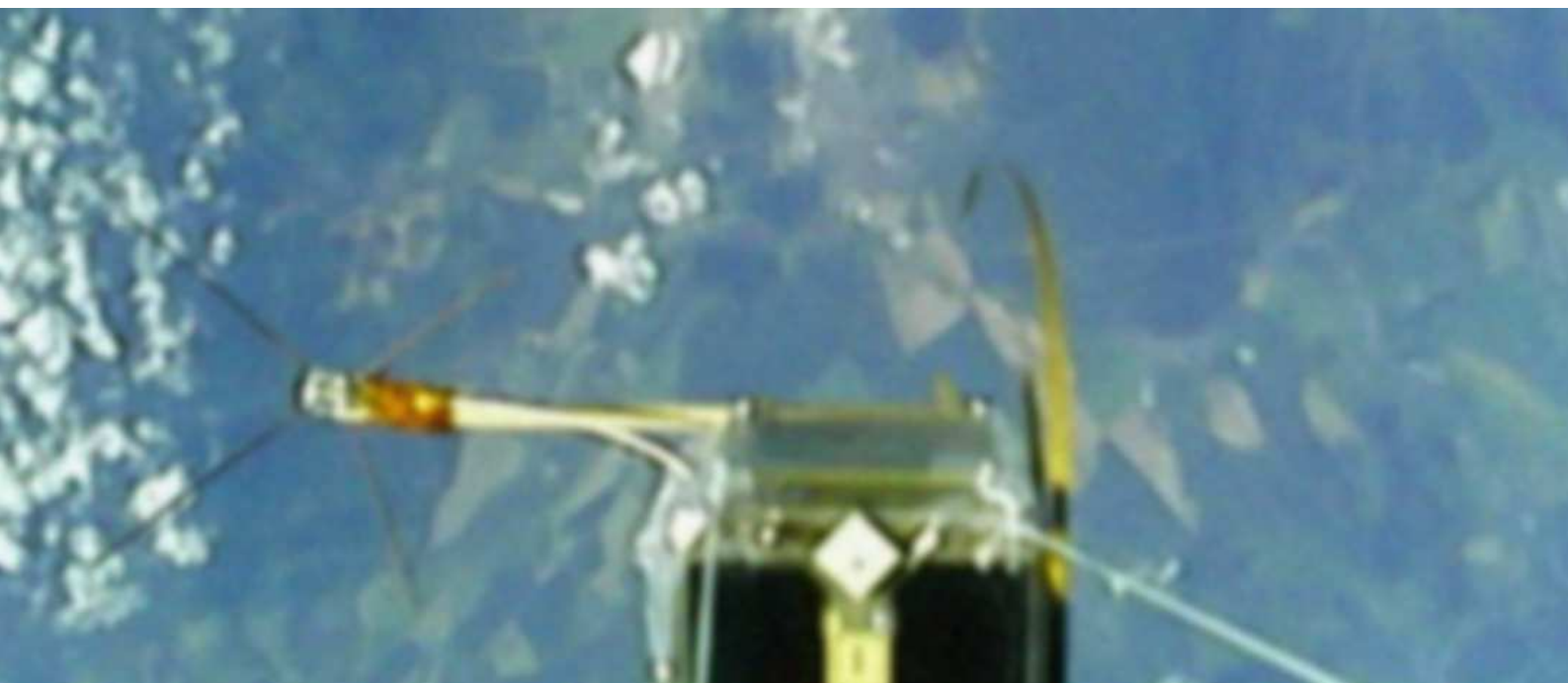

Space-Friendly™
Digital CubeSat Camera
piCAM

Product Datasheet
Rev. B/2022

Intended for **small satellite imaging**.



PRODUCT DATA SHEET

piCAM

FEATURES

- Miniature Digital CubeSat Camera Module
- VGA resolution (640×480px), JPEG data output
- Simple use upon one-byte telecommands
- External LED Flash trigger output via Open-Collector driven signal
- Power consumption
315 mW (typical), 3.3 V @ 25°C
- Easy-to-Implement Data Interface
UART 115200-8-N-1, 3.3V-CMOS levels
- Selectable Bitrate On-the-fly
1k2, 2k4, 9k6, 19k2, 38k4, 57k6,
115k2 (default), 230k4, 460k8, 921k6
- Serial Output packets in ASCII representation of HEX data, divided by CR+LF
- Captures image within 5 seconds
- Evaluation Kit available with White LED Flash driver schematics and Demo
- MOSFET-Free Input Power Switch, allows the unit to be connected permanently to a fixed power bus
- Housekeeping Telemetry readout
 - total input current readout
 - input voltage readout
 - camera module input current readout
 - camera core voltage readout
- Power Supply Input
2.7 to 3.6 V, 3.3V Nominal
- Miniature Dimensions
33×33×19 mm body
+ optics (variable)
- Mounting bracket 48×33 mm with 4×M2.5 mounting holes for easy integration
- STEP model available
- Factory pre-focused to: infinity (default), other distances on request
- Optics with ~60° Field-of-View (default), 116° and 170° optics available, IR-Cut filter included
- Low Unit Mass 40 grams only
- Wide temperature range
-30°C to +85°C
- Connector
6 pin Molex PicoBlade (53261 type)

APPLICATIONS

- Small Satellites, CubeSats, Pico- Nano- Micro- Sats
- Low res Space Imaging
- Civil Scientific High Altitude Balloons
- Educational Imaging
- Educational Weather Monitoring from Space



Fig. 1 Digital CubeSat Camera piCAM, Flight Model.

GENERAL DESCRIPTION

The piCAM is the World's First Space-Friendly™ Digital CubeSat Camera module specially designed to provide the colorful imaging in JPEG format and VGA resolution aboard small satellites with external Flashlight control signal. The unit enables a possibility to trigger signal for external LED-based flashlight to illuminate nearby objects of interest in dark orbital periods, such as solar sails, booms, deployable structures, tethers, etc.

The camera could be delivered as configured with various optics. By default the optics with ~60° Field-of-View (diagonal) with IR-cut filter is attached and fixed, set to focus on infinity. Other configurations or focuses are on prior request during the manufacturing process.

Product is manufactured in two grades to satisfy both Engineering and Flight requirements. Modules (/EM, /FM) are electrically identical, however their chemical and mechanical properties allows it to be used in laboratory or space, respectively.

The fully functional Engineering Model is finished by red coating with Remove Before Flight labelling.

TABLE OF CONTENTS

APPLICATIONS.....	2	FIXED OPTICS.....	10
GENERAL DESCRIPTION.....	2	HIGH ALTITUDE BALLOON (HAB) IMAGE SAMPLES.....	10
TABLE OF CONTENTS.....	3	SUN SYNCHRONOUS ORBIT IMAGE SAMPLES.....	10
ABSOLUTE MAXIMUM RATINGS.....	3	JPEG COMPRESSION.....	11
PARAMETRIC SPECIFICATION.....	3	EVALUATION KIT.....	11
CONNECTOR DESCRIPTION.....	4	APPLICATION NOTES & RECOMMENDATIONS.....	13
FUNCTIONAL BLOCK DIAGRAM.....	5	QUALITY ASSURANCE.....	13
ELECTRICAL INTERFACE & BOOT-UP.....	5	SATELLITE IMAGING.....	15
COMMAND PROTOCOL.....	6	EXPORT CONTROL.....	15
OUTPUT DATA DESCRIPTION.....	6	DISCLAIMER.....	16

ABSOLUTE MAXIMUM RATINGS

V_{DD} to GND.....	-0.3 V to +3.6 V	Other Pins to GND:.....	-0.3 V to $+(V_{DD} + 0.3)$ V
DC Input Voltage: V_I	-0.3 V to $V_{DD} + 0.3$ V (≤ 3.6 V max.)		
DC Output Voltage: V_O	-0.3 V to $V_{DD} + 0.3$ V (≤ 3.6 V max.)		
DC Input Current: I_I at $V_I < 0$ V or $V_I > V_{DD}$	± 120 mA	Operating Temperature Range:.....	-30°C to +85°C
DC Output Current: I_{Flash} at $V_{Flash} < 0$ V or $V_O > V_{DD}$	± 20 mA	Storage Temperature Range:.....	-40°C to +85°C

NOTE: Stresses beyond those listed under “Absolute Maximum Ratings” may cause permanent damage to the device. These are stress ratings only, and functional operation of the device at these or any other conditions beyond those indicated under specification conditions is not implied. Exposure to absolute maximum rated conditions for extended periods may affect device reliability. Voltage values are with respect to system ground terminal.

PARAMETRIC SPECIFICATION

Tab.: 1 **piCAM Parametric Specification summary.**

$T_A = -30^\circ\text{C}$ to $+85^\circ\text{C}$, $V_{DD} = 3.3$ V, unless otherwise noted.

Parameter	Symbol	Min	Typ	Max	Units	Notes/Conditions
Operating Supply Voltage	V_{DD}	2.7	3.3	3.6	V	
Operating Supply Current	I_D		95		mA	
Serial Interface (UART) Bitrate	Bps	1200	115200	921600	BPS	115200-8-N-1 set as default after each boot-up.
Image Resolution	Px	-	640×480	-	Pixels	RGB VGA JPEG 640×480 px.
Maximum Saturation Voltage at Flash Output	$V_{SatFlashMax}$		0.9		V	At $I_{FlashMax} = 20$ mA.
Maximum Open Collector Voltage at Flash Output	$V_{OCFlashMax}$			35	V	
Startup time	$T_{STARTUP}$		5		s	Unit boot-up time.

CONNECTOR DESCRIPTION

The piCAM unit is connected to the target system via single System Interface connector with 6 pins, Molex PicoBlade, 53261 type. Each pin, its function and direction or manner of use is indicated in the Tab.: 2 below. The connector location within the unit is displayed in Fig. 2.

Tab.: 2 **The piCAM Pin Description**, NOTE: Minimum required interface pins are highlighted.

Pin	Name	I/O, Power or Do Not Connect	Description
1	VDD	Power	Main Power Input. +3.3V main input power line, designed to be connected to permanent power bus, as the unit contains internal main power switch. It is however always recommended, to include the Latch-up protection current limiter to protect the power line against Single Event Effects in space.
2	ON	Power	Power ON signal. Log. 1 level will turn ON the input power line power switch - note this signal must be held log. 1 to keep the unit running - when in log 0, the unit is shut off with idle current consumption.
3	RXD	I	UART Data Input TO the Camera. UART data input to the camera - the UART controller must be able to turn off the idle level in order to prevent power bootstrapping of the unit. LVCMOS compatible.
4	TXD	O	UART Data output FROM the Camera. The UART controller must be able to turn off the idle level (pull-up driver) to GND potential in order to prevent power bootstrapping of the unit. LVCMOS compatible.
5	FLASH	I	Flash Open-Collector Input. Holds sink current when the image is being captured, otherwise it is kept open-circuit. BJT based open-collector with 10 ohm protective resistor in series, 20 mA max.
6	GND	Power	Ground potential. Unit casing (including all screws) is galvanically connected to this pin internally.
Chassis	GND	Power	All mechanical/metallic parts are connected together with the GND potential. Connection to camera power ground potential is recommended.

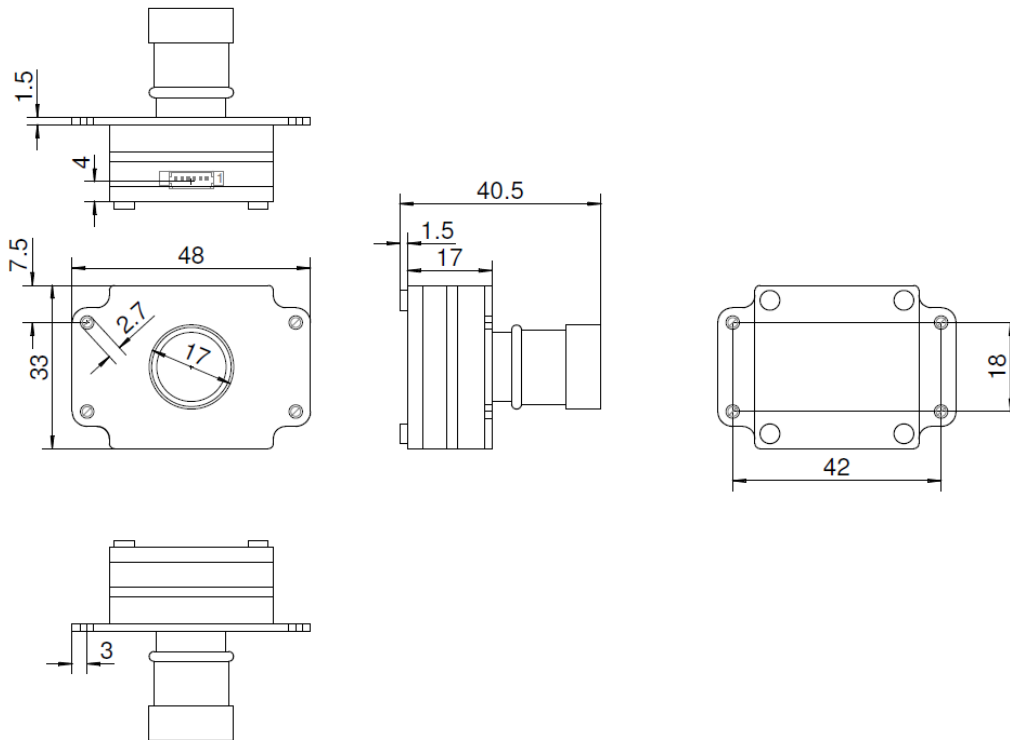

Fig. 2 **The piCAM Dimensions, Connector pinout and recommended footprint.** Dimensions are shown in millimeters. The unit is mount using four M2.5 screws/standoffs. Detailed STEP model is available.

FUNCTIONAL BLOCK DIAGRAM

The key functional blocks of the piCAM are described in Fig. 3. The unit consist of two main blocks: 1) imaging sensor engine and 2) data handling and telemetry engine.

Indicator LEDs are associated to internal status of power. Green LED indicates availability of power to the internal data handling and telemetry engine. Red LED indicates power availability to the imaging sensor engine. Blue LED is available to indicate data transfer, data handling and serves for test purposes (Test Telemetry/Telecommand). Blue LED also indicates activated Flash signal during the image capture. Location of all three LEDs within the unit is shown in Fig. 4.

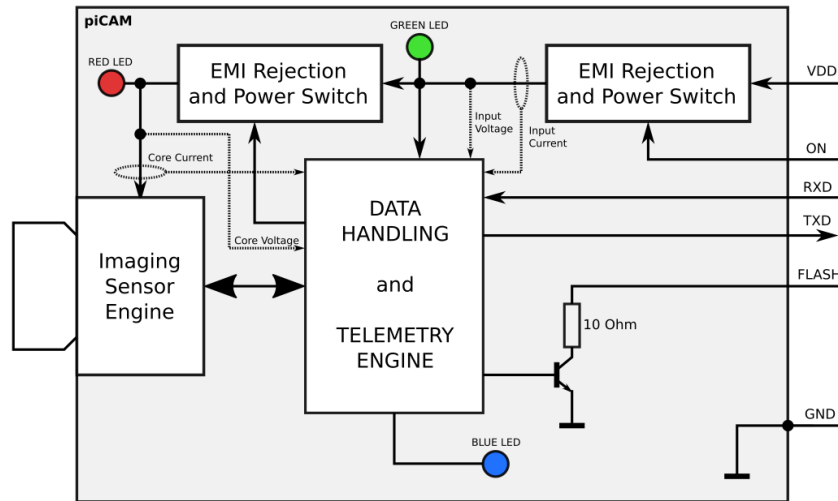

Fig. 3 The piCAM Block Diagram.

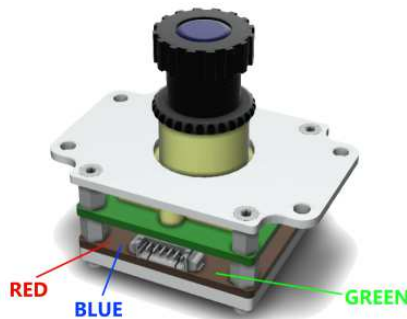

Fig. 4 piCAM Unit, indicator LED locations.

ELECTRICAL INTERFACE & BOOT-UP

When interfacing the piCAM unit, the user needs to consider the effect of power bootstrapping of a typical UART driver. When UART line is idle, it holds the logical level HIGH or 1 (3.3V in case of LVCMOS levels). Such voltage and current capability is able to power up the camera core, which is naturally very low power in order of 5 - 10 mA. Thus, even if the main power input control signal "ON" (pin 2) is held LOW or 0, the bootstrapping via communication interface may still prevent the unit from proper power cycle or restart. It is thus highly recommended to disable the driver of UART interface on both RXD and TXD channels or forcing them directly to zero Volts.

For proper boot-up, following sequence shall be used: the ON, RXD and TXD levels shall be held LOW for at least 1 second. Then ON signal shall be changed into log. 1, followed by activating idle levels (log. 1) on both RXD and TXD channels. Each proper unit boot-up is indicated by three blinks of BLUE LED and with sending Initial Informal Sentence towards the onboard computer.

COMMAND PROTOCOL

The physical communication is realized via the standard bidirectional UART data interface. The bitrate is set to **115200 bps, no parity, 8 data bits, 1 stop bit (115200-8-N-1) as default after each successful unit boot-up**. Logical levels are equal to LVCMOS levels as defined in JEDEC JESD8C.01 standard.

Telecommanding is realized based on a set of single byte commands as summarized in Tab.: 3. There is a total of six commands for image capture brightness sensitivity and flash settings for daylight, medium and night regime, with and without activated flash output.

The test telecommand is useful tool to check the proper bidirectional connection in flight and is also able to activate the flash circuits during ground tests and satellite development.

The unit is able to modify the communication bitrate, from as low as 1200-8-N-1 up to 921600-8-N-1 in ten different steps. When such telecommand is issued, the unit switches to a new bitrate and the user UART interface driver needs to rearrange the bitrate as well in order to communicate at new bitrate.

Keep at least **20 ms** between the change bitrate telecommand and the moment a new telecommand is issued.

Tab.: 3 piCAM Set of single byte Telecommands.

ASCII Character	Command Description
Image Capture Telecommands	
d	Captures image with daylight ambient light optimal settings without Flash activated during the image capture
D	Captures image with Daylight ambient light optimal settings with Flash activated during the image capture
m	Captures image with medium ambient light optimal settings without Flash activated during the image capture
M	Captures image with Medium ambient light optimal settings with Flash activated during the image capture
n	Captures image with night ambient light (darkness) optimal settings without Flash activated during the image capture
N	Captures image with Night ambient light (darkness) optimal settings with Flash activated during the image capture
s	Captures image with solar sail contrast and light optimal settings without Flash activated during the image capture
S	Captures image with Solar sail contrast and light optimal settings with Flash activated during the image capture
Test Telecommands	
t	Returns test string with telemetry measurement, module LED blinking and without activated Flash
T	Returns test string with telemetry measurement, module LED blinking and with activated Flash (Flash test)
Bitrate Change Telecommands	
0	Change from current bitrate to: 1200bps-8-n-1
1	Change from current bitrate to: 2400bps-8-n-1
2	Change from current bitrate to: 9600bps-8-n-1
3	Change from current bitrate to: 19200bps-8-n-1
4	Change from current bitrate to: 38400bps-8-n-1
5	Change from current bitrate to: 57600bps-8-n-1
6	Change from current bitrate to: 115200bps-8-n-1 (default after boot-up)
7	Change from current bitrate to: 230400bps-8-n-1
8	Change from current bitrate to: 460800bps-8-n-1
9	Change from current bitrate to: 921600bps-8-n-1

OUTPUT DATA DESCRIPTION

The camera module via its telemetry engine provides serialized image information upon uplinking telecommand. As extension, the telemetry sentence is provided in order to measure the unit internal voltages, operational currents and image size and image processing information. Data is sent in fixed length format consisting of 67 bytes per sentence (including CR+LF characters) in order to simplify the parsing process.

Output is represented by user-readable ASCII character form and thus could be easily displayed using computer with various terminal software for COM port data reception and stored easily in satellite onboard computer memory storage space. Post-parsing of image data sentences is necessary in order to extract and compile the whole JPEG image.

The unique sentence identification numbering shall support the user to simplify the reconstruction of the JPEG image process, especially in remote telemetry downlink attempts from satellite memory. As first after boot-up, the unit sends the initial informal sentence set, as follows:

INITIAL INFORMAL SENTENCE (sent after each successful boot-up sequence)

```

←↵
@-----↵↵
@| piCAM/FM (c) SkyFox Labs s.r.o., 2021 - Unit Boot-Up FW v7.0 |↵↵
@-----↵↵
    
```

The image data is provided upon telecommand in following format:

DIGITAL OUTPUT EXAMPLE (6 sentences shown only, 67 bytes each)

```
@000003DEFFD8FFDB0084000D09090B0A080D0B0A0B0E0E0D0F13201513121213 ←↵
@000103DE271C1E17202E2931302E292D2C333A4A3E333646372C2D405741464C ←↵
@000203DE4E525352323E5A615A50604A51524F010E0E0E131113261515264F35 ←↵
@000303DE2D354F4F4F4F4F4F4F4F4F4F4F4F4F4F4F4F4F4F4F4F4F4F4F4F4F4F ←↵
@000403DE4F4F4F4F4F4F4F4F4F4F4F4F4F4F4F4F4F4F4F4F4F4F4F4FFFC401A2 ←↵
@000503DE0000010501010101010101000000000000000000102030405060708090A ←↵
```

- @ packet initial character (#40h),
1 byte, fixed length,
- nnnn** where *nnnn* means ASCII representation of HEX number of current sentence, always starts at address 0000,
4 bytes, fixed length,
- xxxx** where *xxxx* means ASCII representation of HEX total amount of image sentences in captured image data stream, 0x03DEh = 990 image sentences (0x0000h to 0x03DDh) + 1 telemetry sentence (0x03DEh),
4 bytes, fixed length,
- data** where *data* means 2 byte-ish consecutive ASCII representation stream of HEX byte of raw captured image data, 28 bytes of raw image data, ie.: 0xFFh = 255, 0xD8h = 216, etc.,
56 bytes, fixed length,
- ← CR character (#0Dh),
1 byte, fixed length,
- ↵ LF character (#0Ah),
1 byte, fixed length.

At the end of each image data stream, the telemetry is captured and sentence compiled and provided in following format:

TELEMETRY SENTENCE (1 sentence per each image data stream, always sent as the last one)

```
@FACE03DE1E006C4700112233445566778899AABBCCDDEEFF00A35B9F4D000670 ←↵
```

- @ packet initial character (#40h),
1 byte, fixed length,
- FACE** where *FACE* indicates the last sentence number,
4 bytes, fixed length,
- xxxx** where *xxxx* means ASCII representation of HEX total amount of image sentences in captured image data stream,
0x03DE = 990 image sentences (0x0000 to 0x03DD) + 1 telemetry sentence (0x03DE),
4 bytes, fixed length,
- tries** where *tries* means 2 byte ASCII representation of HEX byte of number of internal communication sync tries, (0x1E = 0d30), may vary up to 0xFF,
2 bytes, fixed length,
- iiiiii** where *iiiiii* means ASCII representation of HEX total amount of JPEG image raw bytes,
0x006C47 = 27719 raw bytes of final JPEG image,
6 bytes, fixed length,

stuffing	where <i>stuffing</i> means fixed string of characters to byte-stuff the sentence length, 32 bytes, fixed length,
00	fixed byte separator, always 00, 2 bytes, fixed length,
InputVoltage	where <i>InputVoltage</i> means ASCII representation of HEX byte, equals to unit main power bus input voltage by following formula: $V = \text{InputVoltage} * 0,02$ [V] i.e. 0xA3 = 0d163, $V = 163 * 0,02 = 3,26$ V, 2 bytes, fixed length,
InputCurrent	where <i>InputCurrent</i> means ASCII representation of HEX byte, 0xA3 = 0d163, equals to unit main power bus input current by following formula: $I = \text{InputCurrent}$ [mA] i.e. 0x5B = 0d91, $I = 91$ mA, 2 bytes, fixed length,
CoreVoltage	where <i>CoreVoltage</i> means ASCII representation of HEX byte, equals to unit core power bus input voltage by following formula: $V = \text{CoreVoltage} * 0,02$ [V] i.e. 0x9F = 0d159, $V = 159 * 0,02 = 3,18$ V, 2 bytes, fixed length,
CoreCurrent	where <i>CoreCurrent</i> means ASCII representation of HEX byte, equals to unit core power bus input current by following formula: $I = \text{CoreCurrent}$ [mA] i.e. 0x4D = 0d77, $I = 77$ mA, 2 bytes, fixed length
00	fixed byte separator, always 00, 2 bytes, fixed length,
Flash	where <i>Flash</i> indicates whether the image was captured using activated Flash illumination (0x01 = 0d01), or without Flash (0x00 = 0d00) 1 byte, fixed length,
Baudrate	where <i>Baudrate</i> indicates at which baudrate the image was telecommanded to and downlinked from the camera according to following baudrate list: <ul style="list-style-type: none"> 0 = 1200bps-8-n-1, 1 = 2400bps-8-n-1, 2 = 9600bps-8-n-1, 3 = 19200bps-8-n-1, 4 = 38400bps-8-n-1, 5 = 57600bps-8-n-1, 6 = 115200bps-8-n-1 (default after power up), 7 = 230400bps-8-n-1, 8 = 460800bps-8-n-1, 9 = 921600bps-8-n-1, 1 byte, fixed length,
FW Version	where <i>FW Version</i> indicates the camera unit firmware version installed, 0x70 = FW v 7.0 2 bytes, fixed length,
↵	CR character (#0Dh), 1 byte, fixed length,
↵	LF character (#0Ah), 1 byte, fixed length.

TEST SENTENCE EXAMPLES (Flash ON / OFF)

@-----	←↵
@ piCAM/FM Test String Transmission - Flash ON A7080000001670	←↵
@-----	←↵
@-----	←↵
@ piCAM/FM Test String Transmission - Flash OFF A7080000000670	←↵
@-----	←↵

InputVoltage where *InputVoltage* means ASCII representation of HEX byte, equals to unit main power bus input voltage by following formula: $V = \text{InputVoltage} * 0,02$ [V],
 i.e. 0xA3 = 0d163, $V = 163 * 0,02 = 3,26$ V,
 2 bytes, fixed length,

InputCurrent where *InputCurrent* means ASCII representation of HEX byte, equals to unit main power bus input current by following formula: $I = \text{InputCurrent}$ [mA],
 i.e. 0x08 = 0d08, $I = 8$ mA,
 2 bytes, fixed length,

CoreVoltage where *CoreVoltage* means ASCII representation of HEX byte, equals to unit main power bus input voltage by following formula: $V = \text{CoreVoltage} * 0,02$ [V],
 i.e. 0x00 = 0d00, $V = 0 * 0,02 = 0$ V,
 2 bytes, fixed length,

CoreCurrent where *CoreCurrent* means ASCII representation of HEX byte, 0xA3 = 0d163, equals to unit main power bus input current by following formula: $I = \text{CoreCurrent}$ [mA],
 i.e. 0x00 = 0d00, $I = 00$ mA,
 2 bytes, fixed length,

00 fixed byte separator, always 00,
 2 bytes, fixed length,

Flash where *Flash* indicates whether the test was captured using activated Flash illumination (0x01 = 0d01), or without Flash (0x00 = 0d00),
 1 byte, fixed length,

Baudrate where *Baudrate* indicates at which baudrate the test was telecommanded to and downlinked from the camera according to following baudrate list:
 0 = 1200bps-8-n-1,
 1 = 2400bps-8-n-1,
 2 = 9600bps-8-n-1,
 3 = 19200bps-8-n-1,
 4 = 38400bps-8-n-1,
 5 = 57600bps-8-n-1,
 6 = 115200bps-8-n-1 (default after power up),
 7 = 230400bps-8-n-1,
 8 = 460800bps-8-n-1,
 9 = 921600bps-8-n-1,
 1 byte, fixed length,

FW Version where *FW Version* indicates the camera unit firmware version installed,
 0x70 = FW v 7.0
 2 bytes, fixed length

← CR character (#0Dh),
 1 byte, fixed length,

↵ LF character (#0Ah),
 1 byte, fixed length.

FIXED OPTICS

The piCAM is designed to hold the S-mount lens with a fixed focal length, pre-adjusted during the manufacturing upon customer requirement of the focal distance. As a standard, the focus is set and glue-fixed to infinity. Lens contain the IR-cut filter. There are a variety of lens focal length options with variety of associated fields-of-view (FoV). As a standard, 60° FoV optics with IR-cut filter is utilized. Examples of three major types of FoVs available are mentioned in Fig. 5.



Fig. 5 The Prague Castle captured with different optics from the same spot, (FoV example: 21° left, 60° middle, 170° right).

HIGH ALTITUDE BALLOON (HAB) IMAGE SAMPLES

There are three examples of the image captured using imagery mode "Middle", 60° FoV optics and IR-Cut filter during the HAB flight at an altitude of ~25 km above ground. Residual atmosphere is visible in Fig. 6.



Fig. 6 High Altitude Balloon flight image data with residual atmosphere, 60° FoV Optics with IR-Cut filter.

SUN SYNCHRONOUS ORBIT IMAGE SAMPLES

The plot in Fig. 7 shows data from the Sun Synchronous Orbit (SSO) 530 km flight of the CubeSat spacecraft (NORAD ID 44406), identifying several regions over Europe, including direct sunlight image capture.



Fig. 7 Examples of real in-orbit image captures using standard optics with IR-cut filter, Sun Synchronous Orbit. [Lucky-7 Spacecraft mission].

JPEG COMPRESSION

The camera compression into JPEG is optimized to naturally occurring sceneries, to maximize the image quality, luminance and contrast balancing as well as the level of image compression in order to produce minimum image size. As the JPEG compression is naturally lossy, there might be scenes with super fast changing moiré of black and white colors changing rapidly within the imager raster. Even if the JPEG compressor has been optimized for various scenes and optical conditions and multiple times tested in space (as also depicted in Fig. 5, Fig. 6 and Fig. 7), there might be such a complicated scene where the compressor may not be able to interpret properly all the lining periodicity or corrupt the line scan interpretation in certain parts of the image.

To suppress the rapid change in scenery contrast following measures could be implemented in order to reduce the pattern periodicity: at night/dark conditions of orbit, use a proper setup of LED Flash illumination brightness (dim, low power LEDs) in case of aluminum-coated foils, setting up the lowest (Solar Sail) brightness and contrast mode of image capture ("s" or "S"), or adjusting the optics during the manufacturing in order to reduce the focus from super sharp to ~90%, i.e. a ~10% blur applied, with focus positioned slightly in front or after the target to be captured. Among the terrain or atmospheric weather monitoring cases, it is recommended to test the imaging of the target prior flight in order to confirm the correctness of the resulting image, in case a super shiny foil with rapidly changing moiré is expected to be imaged. In Fig. 8 there are examples of complete aluminum-coated foil captures using 60° and 170° FoV optics in order to demonstrate that the JPEG compressor is able to process the image correctly.



Fig. 8 Example of Aluminum-coated foil with rapid moiré changing patterns. Daylight conditions (left), night/darkness conditions (middle and right) with Evaluation Kit LED Flashlight activated. Foil size 3×2 m, 1 m distance.

EVALUATION KIT

EVAL KIT BASICS

The piCAM Evaluation Kit in Fig. 9 has been developed to support customers with Camera module implementation together with the serial parsing and image processing software development in engineering and breadboarding phases. It enables user to easily connect and power the unit from the USB and communicate via established Virtual COM Port (VCP). Current consumption measurement and output data waveforms can be captured by conventional ammeter and scope using current sensing and serial port pin headers.

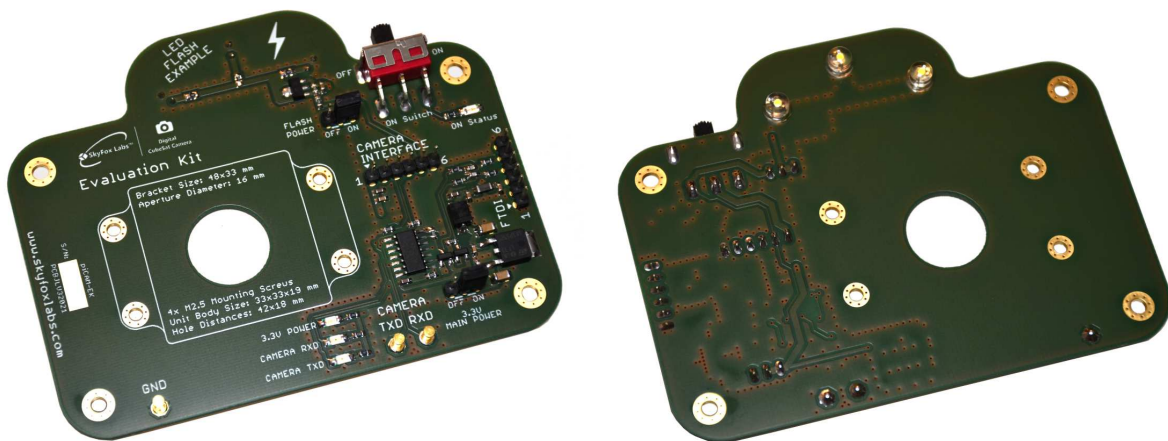

Fig. 9 The piCAM Evaluation Kit Front (left), Back (right) with set of 3 White Wide Angle LEDs on top.

EVAL KIT SCHEMATICS

The Eval Kit contains the example of fully functional Flash driver with three white wide-angle LEDs in order to capture images in darkness, as depicted in Fig. 10. At the highest sensitivity mode (Night) it is able to illuminate and capture images of typical household / laboratory / office objects up to 5 meters, similar to daylight.

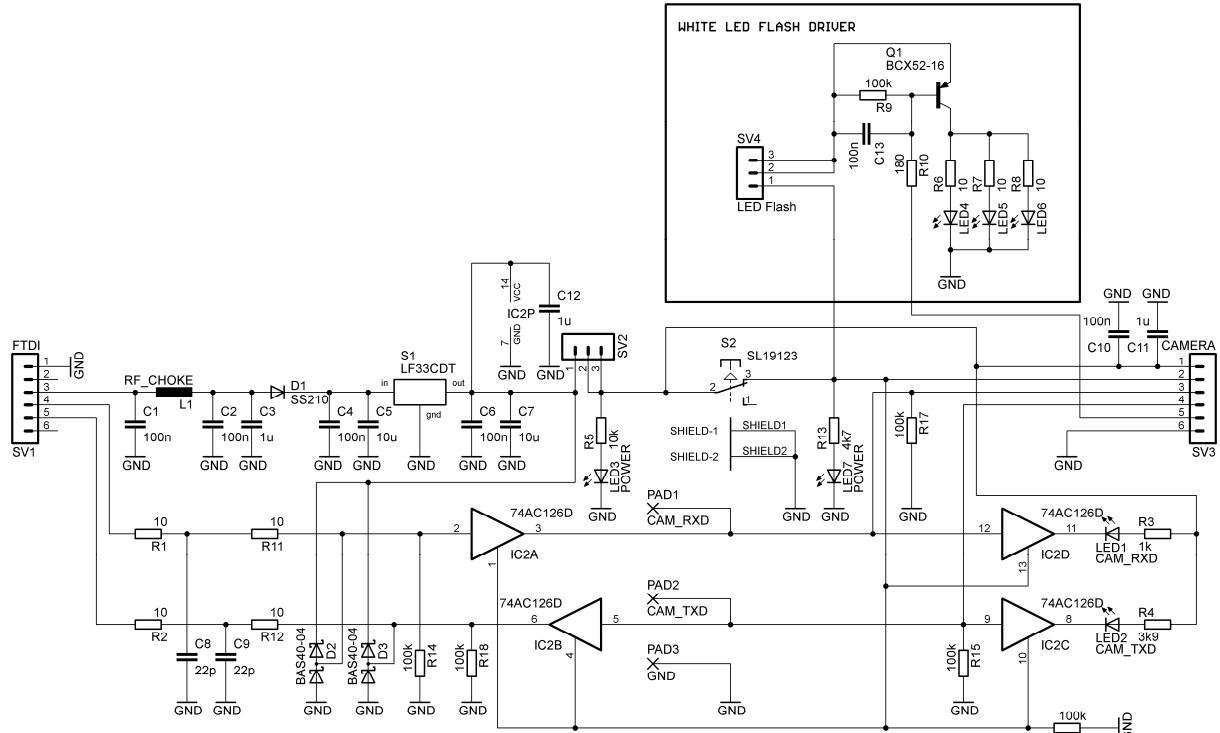

Fig. 10 piCAM Evaluation Kit Schematics with highlighted 3.3V LED Flash Driver Example circuitry.

EVAL KIT PC SOFTWARE

Associated Win PC SW has been developed in order to maximize the simplicity of product evaluation. The piCAM Eval Kit Demo SW is straightforward and shown in Fig. 11. After installation of Virtual COM Port drivers under Windows, the COM port needs to be assigned in order of 1 to 16 for proper operations. The maximum available bitrate of the PC SW is 115200-8-N-1.

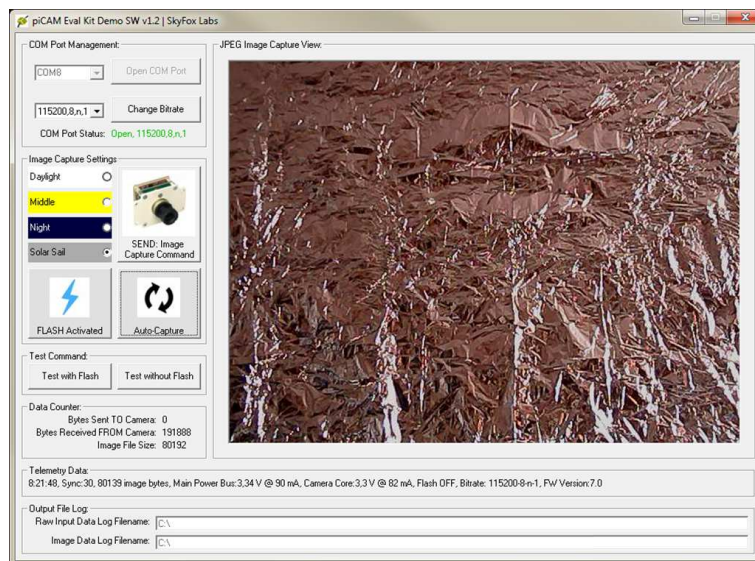

Fig. 11 The piCAM Evaluation Kit Demonstration software screenshot.

APPLICATION NOTES & RECOMMENDATIONS

MECHANICAL AND THERMAL CONSIDERATIONS

As the unit is designed to operate in industrial temperature range (-40 to +85°C), the user shall maintain this temperature range during the flight to fit this requirement. The unit mounting bracket is recommended to be screwed and fixed by a total of four standoffs to and within the satellite body, to insulate it from the external parts. The optics shall penetrate the satellite wall with no direct touching. A practical gap of 1 mm at all sides is recommended between the camera optics and the outer satellite wall via aperture in order to prevent thermal bridging and maintain safety margin for vibration wiggle during the test campaign and launch as in Fig. 12.



Fig. 12 An example of the satellite wall aperture with piCAM optics and 1 mm thermal gap.

EMC CONSIDERATIONS

The electromagnetic susceptibility and compatibility is critical for implementation of any subsystems sensitive to electromagnetic radiation. Proper ground planes and PCB design rules minimizing the radiated and conducted emissions shall be applied within the whole small satellite structure, including custom payloads, conventional (Communication and Data Handling, Power Supply and Power Distribution, Onboard Computer, Attitude Determination and Control) and third party electronic subsystems. Screw heads from bottom side of target PCB shall be galvanically connected with ground potential. GND potential is already connected between electronic board and casing.

OPTICAL CLEANLINESS

Before flight and during integration phase, always keep in mind the requirement of a very high cleanliness to prevent any mechanical or dusty residuals to stay attracted to the optics. Use soft fabrics for optical instruments to carefully clean the surface of the optics, if necessary.

QUALITY ASSURANCE

GENERAL INFORMATION

Since the piCAM has been designed for the operation in space environment as a specially featured electronic device based on Commercial Off-the-Shelf (COTS) components, the special care is taken to follow the standardized space-grade product assembly procedures, materials and components where possible (i.e. no Radiation Hardened integrated circuits or parts are used). It is recommended to control the possible single event latchups of the unit based on overcurrent/overload monitoring on the unit main power / control signal inputs.

MATERIALS

Components are soldered on the 4- and 2-layers FR4 PCBs, using 60/40% (Tin/Lead) compound. Gray 3M Scotch Weld Epoxy is used for mechanical fixings and PCB coating to prevent outgassing.

Vacuum-proof electronic components from ESA and NASA-preferred vendors are used (i.e. no electrolytic capacitors) in industrial temperature grade, where possible.

PROCESSES

The Flight Model is hand soldered, assembled in 100.000 Class Clean Room by the ESA-certified personnel. The PCB is then cleaned using the Isopropyl Alcohol, programmed and tested. Post production burn-in screening test is performed under nominal operating conditions and room temperature.

PACKAGING & SHIPPING

Once the piCAM successfully passes the screening test, it is finally cleaned, optically inspected and shipped encapsulated in ESD protective packaging.

SATELLITE IMAGING

Always follow the local / global laws and regulations regarding the satellite imagery, processing and handling applied in country of use or else, before use (flight). By no means the manufacturer shall be responsible for any misuse of the imagery or product use. The unit captures the image in resolution of RGB matrix of 640×480 pixels (matrix of 640×480×4 image cells, i.e. less than 2 megapixels in total).

EXPORT CONTROL

Since the country of origin of this product (the Czech Republic) is a valid participating member of the Wassenaar Agreement (<http://www.wassenaar.org>) and agrees with the Missile Technology Control Regime (<http://www.mtcr.info>) and the **piCAM (Space-grade Flight Model)** functional parameters are considered as a regulated goods, the export is controlled and needs special Export License approved by the Ministry of Industry and Trade of the Czech Republic (the local control entity). The request for the Export License has to be submitted by the manufacturer to the local control entity, based on the binding order, including all the information as: the characteristics of goods, target country (territory), detailed end-user and target application information, etc.

Manufacturer is fully prepared to support the customer with obtaining the valid Export License (if approved by the local control entity). The entity declares the typical Export License assessing period from 30 to 60 days since the Export License Application Form delivery, implicating the respective product delivery date extension.

DISCLAIMER

THIS IMAGING DEVICE IS NOT INTENDED TO SERVE AS SPYING OR LIFE OR PROPERTY MONITORING OR RELATED USE MONITORING UNIT. THIS DEVICE HAS BEEN DEVELOPED WITH IDEA TO SUPPORT THE SMALL SATELLITE COMMUNITY EFFORT IN SPACE RELATED RESEARCH, ENGINEERING AND PEACEFUL CONQUEST OF SPACE. THE MANUFACTURER RESERVES ALL RIGHTS TO DECLINE THE ORDER OF THIS PRODUCT OR PROVIDE ANY FURTHER INFORMATION TO END USERS ASSUMING TO VIOLATE ANY LOCAL OR GLOBAL NATIONAL LAWS BY THIS DEVICE OR INFORMATION MENTIONED IN THIS AND RELATED DOCUMENTS. MANUFACTURER DOES NOT ASSUME ANY LIABILITY ARISING OUT OF THE APPLICATION OR USE OF THIS PRODUCT OR CIRCUIT DESCRIBED HEREIN; NEITHER DOES IT CONVEY ANY LICENSE UNDER ITS PATENT RIGHTS, NOR THE RIGHTS OF OTHERS. MANUFACTURER RESERVES THE RIGHT TO MAKE CHANGES OF THIS PRODUCT DATASHEET WITHOUT FURTHER NOTICE.



Prague, Czech Republic

© 2014-2022 SkyFox Labs, All rights reserved.